

# **LUBRICATION (H4SO)**

### 1. General

- The lubrication system forcibly circulates engine oil throughout the engine using an oil pump. The oil pressure is regulated by the relief valve built into the oil pump.
- The oil pump is a thin, large-diameter trochoid rotor type which can accommodate the engine's high output. The pump is directly driven by the crankshaft.
- The engine oil is cleaned by a full-flow, paper element type oil filter. The filter has a bypass valve, which allows the engine oil to flow bypassing the filter if it is clogged.
- The inside of the oil pan is fitted with a baffle plate, which reduces changes in the oil level due to movement of the vehicle, thus ensuring uninterrupted suction of oil.
- The engine oil discharged from the oil pump is delivered to the journal bearings, connecting rod bearings, and other parts requiring lubrication and cooling through the oil filter, vertical passage in the right bank of the cylinder block, and the oil galleries in the right and left banks of the cylinder block.
- The engine oil is also distributed to each cylinder head valve mechanism at a proper flow rate achieved by metering by the orifice provided in each oil gallery.

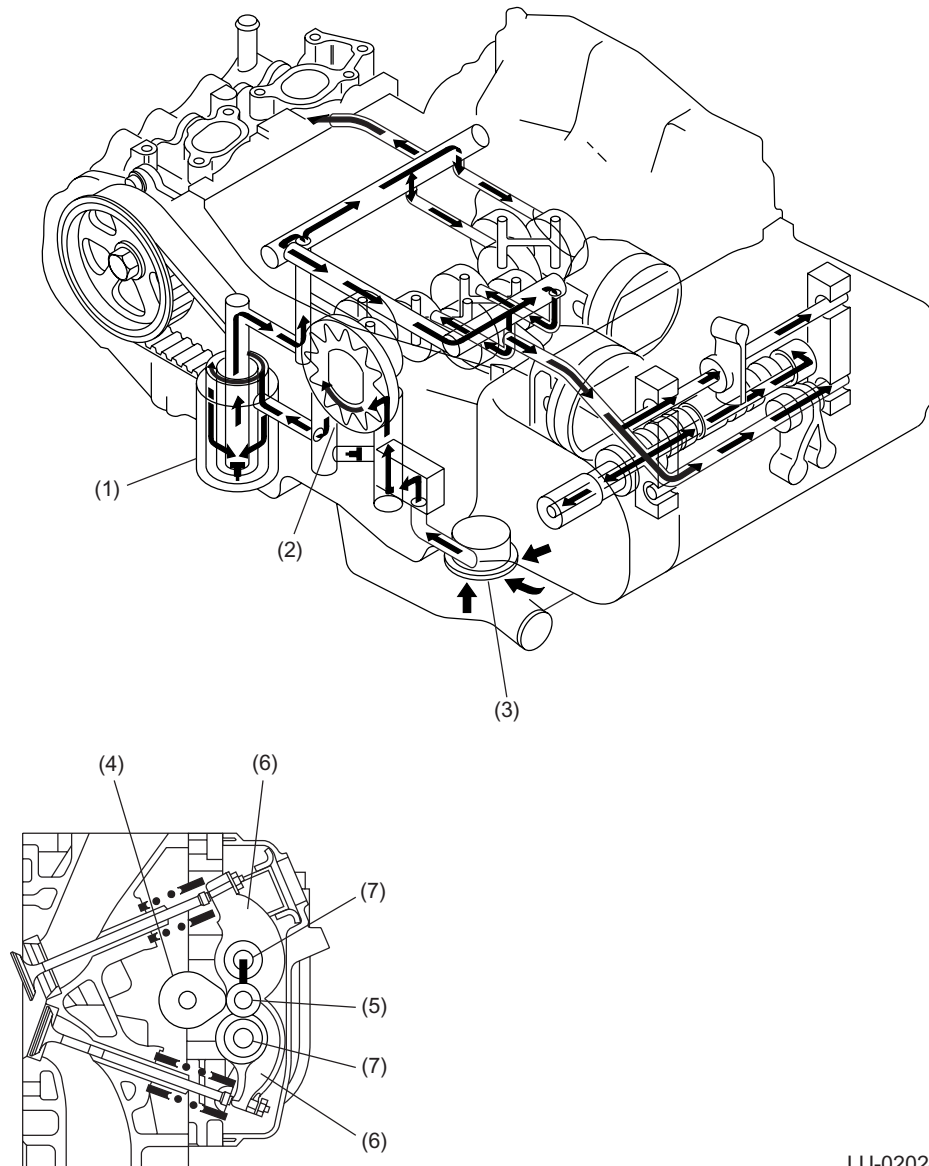

LU-02024

- (1) Oil filter
- (2) Oil pump
- (3) Oil strainer
- (4) Camshaft

- (5) Roller
- (6) Rocker arm
- (7) Rocker shaft

# ENGINE OIL FLOW

LUBRICATION

## 2. Engine Oil Flow

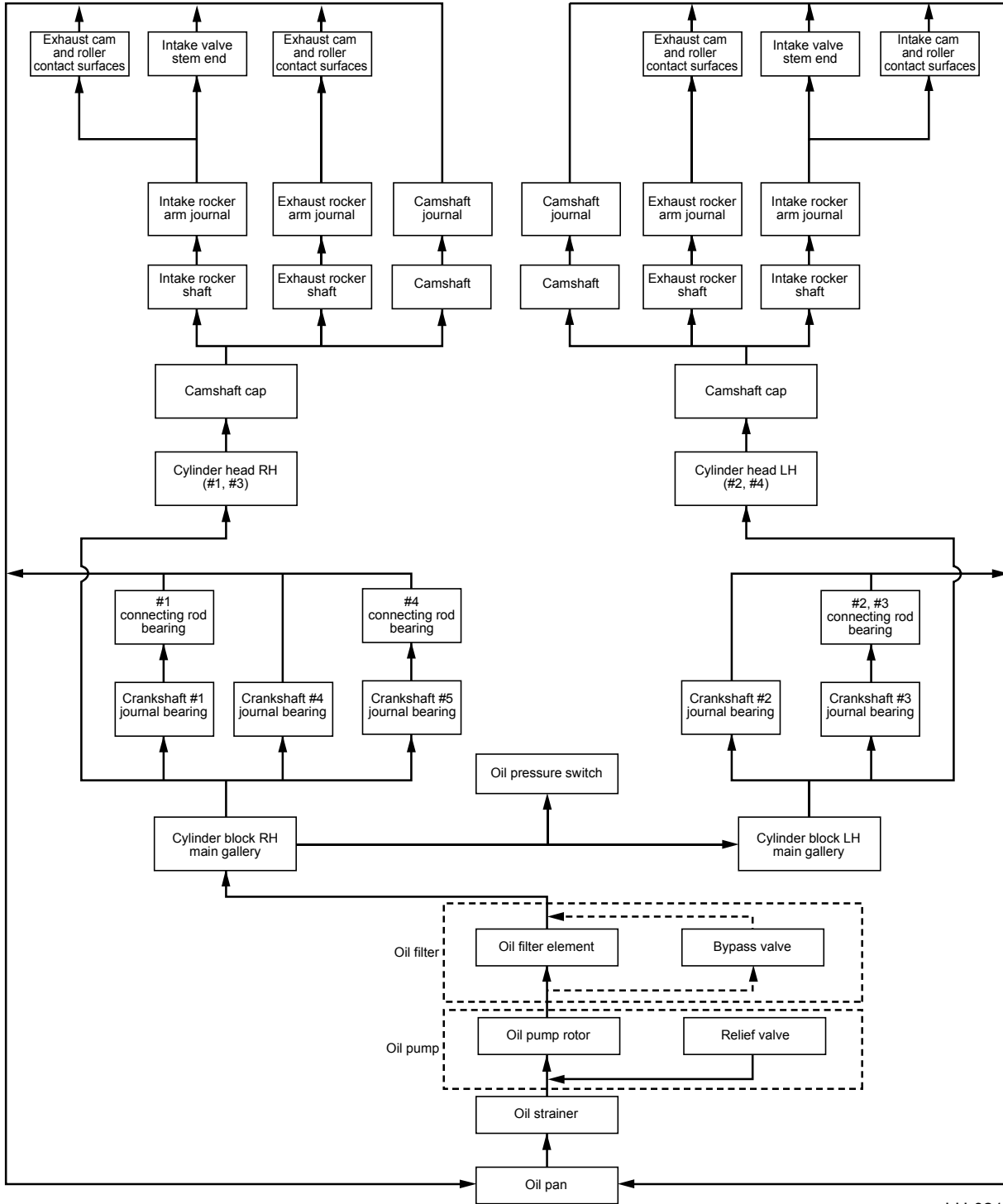

LU-02109

## 3. Oil Pump

- The oil pump is a trochoid rotor type consisting of an inner rotor and outer rotor assembled with each other in a pump body. When the inner rotor is driven by the crankshaft, the outer rotor is rotated, changing the space between it and the inner rotor. The change in the space occurs because of the difference in the number of teeth between the rotors.
- Engine oil is carried from the inlet port to the discharge port. As the pump rotates, the space carrying the oil becomes smaller, thus the oil is pressurized and discharged from the discharge port. A relief valve is built in the oil pump at its discharge side. When the oil pressure becomes higher than the preset value, the relief valve regulates the pressure by sending excessive oil back to the inlet side.

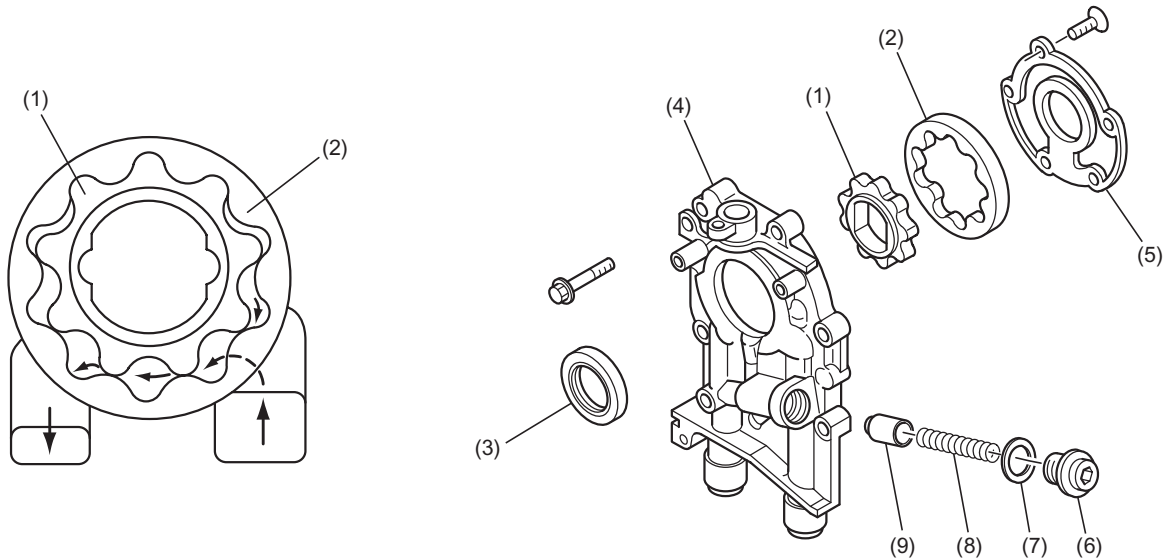

LU-00058

- (1) Inner rotor
- (2) Outer rotor
- (3) Oil seal
- (4) Oil pump case
- (5) Oil pump cover

- (6) Plug
- (7) Gasket
- (8) Relief valve spring
- (9) Relief valve

# OIL FILTER

## 4. Oil Filter

The oil filter is a full-flow filtering, cartridge type that utilizes a paper element. It also has a built-in bypass valve. If the filter gets clogged causing the oil pressure to exceed the preset value, the bypass valve opens and detours the engine oil to flow around the filter. The filter element has a special pleat design to increase the effective filtering area.

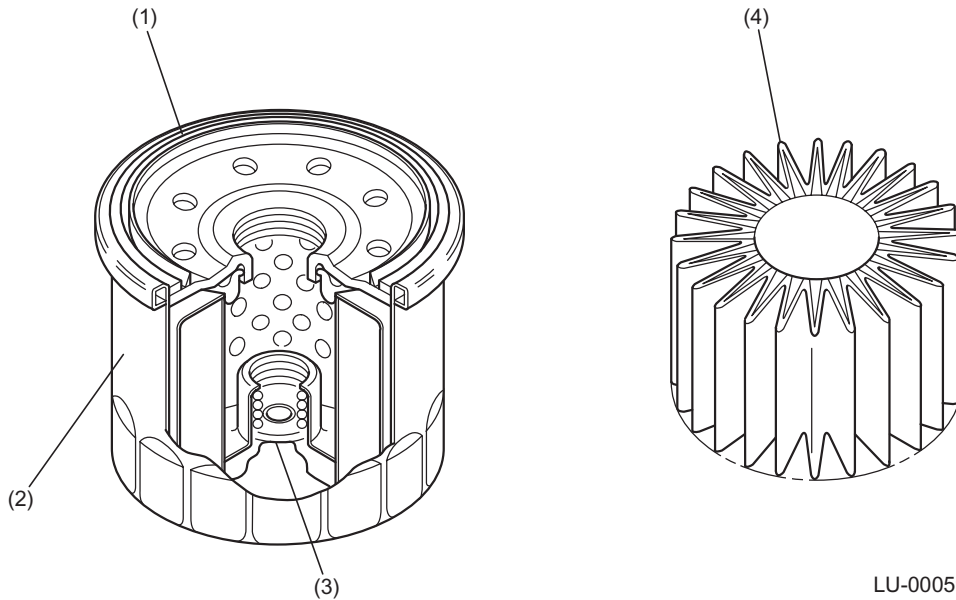

- (1) Oil seal
- (2) Filter body
- (3) Bypass valve
- (4) Pleated element

LU-00059

## 5. Oil Pan and Oil Strainer

- The oil pan is attached to the cylinder block using liquid gasket for sealing. The oil strainer is a metal net type and removes large foreign particles from the engine oil. It is located in the middle of the oil pan. The pipe from the strainer is connected to the suction port of the oil pump in the left bank of the cylinder block.
- There is a baffle plate inside the oil pan. It stabilizes the oil level and reinforces the oil pan.

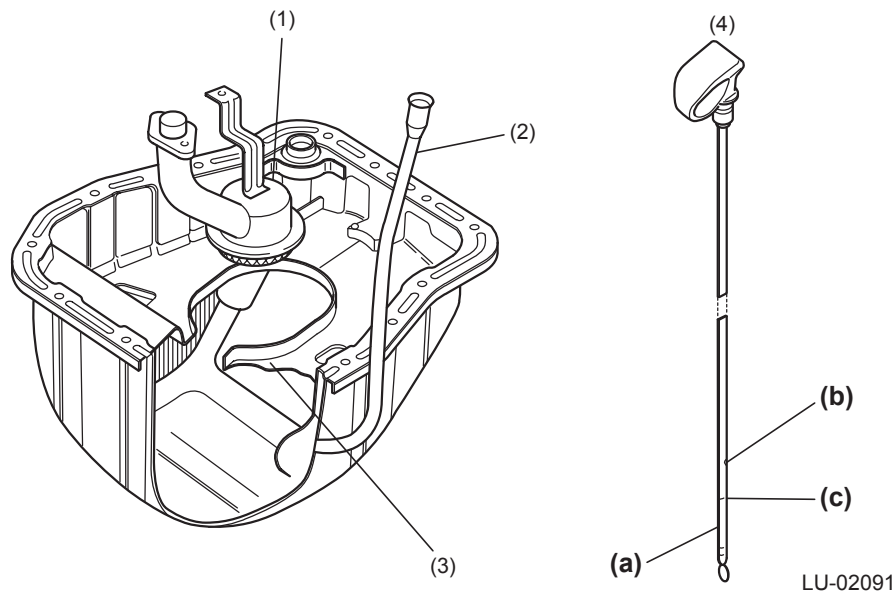

- (1) Oil strainer
- (2) Level gauge guide
- (3) Baffle plate
- (4) Oil level gauge

- (a) LOW level
- (b) FULL level (engine hot condition)
- (c) FULL level (engine cold condition)

# OIL PRESSURE SWITCH

LUBRICATION

## 6. Oil Pressure Switch

The oil pressure switch is located in the front upper portion of the right cylinder block bank. The purpose of this switch is to monitor the operation of the oil pump as well as the lubricating oil pressure when the engine is running.

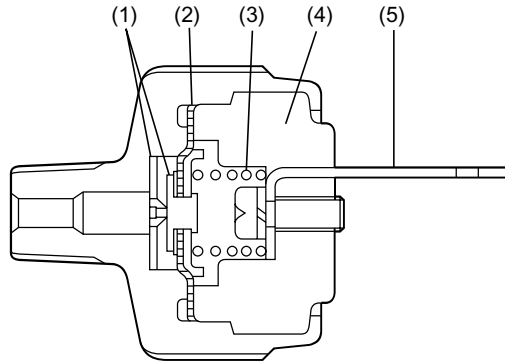

LU-00061

- |               |                    |
|---------------|--------------------|
| (1) Contact   | (4) Molded portion |
| (2) Diaphragm | (5) Terminal       |
| (3) Spring    |                    |

1) When oil pressure does not build up (immediately after ignition switch is turned ON):  
The diaphragm is pushed toward the cylinder block by the spring force (a force equivalent to the specified oil pressure). This closes the contact points, causing the oil pressure warning light in the combination meter to illuminate.

2) When oil pressure reaches the specified value (after engine starts):  
After reaching the specified value, the oil pressure pushes the diaphragm against the spring force. This opens the contact points and the oil pressure warning light goes out.